

SERIES - MI-H-SF

STRAIGHT BASE FIXED HOLD DOWN ARM

Supplied with Spindle assemblies. Clamp runs with specially designed pre-lubricated bushes for long life cycle. Silicon rubber grip having large grip surface with oil & heat resistance.

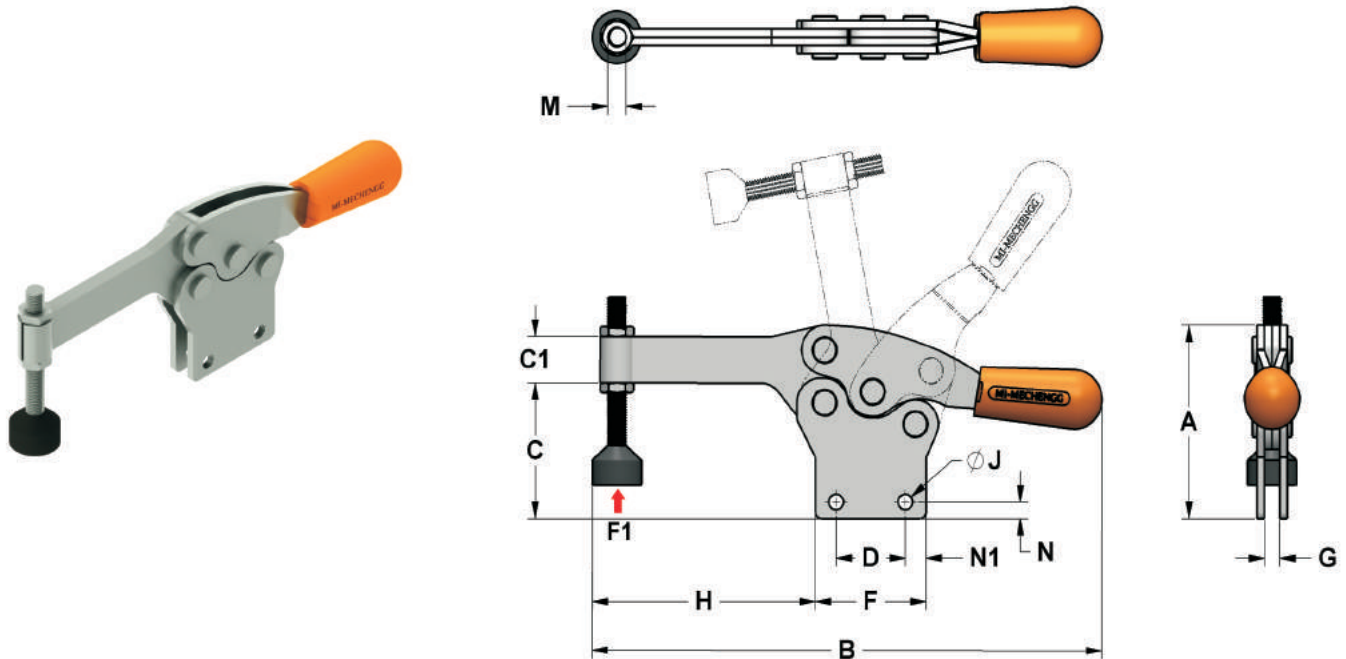

- **Material** : Steel
- **Surface Finish** : Electro Zinc - Plated
- **Hand Grip** : Silicon Rubber
- **Clamping Bolt** : 8.8 Grade Moulded with NBR

PART NO	ARM OPENS	HANDLE MOVES	HOLDING CAPACITY F1 (N)	APPROX (Kg's)	SPINDLE SUPPLIED (METRIC) PART NO
MI-H-75-SF	79°	53°	0350	0.160	NTS-H75
MI-H-150-SF	79°	56°	0750	0.235	NTS-H150
MI-H-250-SF	88°	58°	1000	0.335	NTS-H250
MI-H-350-SF	89°	56°	1780	0.915	NTS-H350
MI-H-650-SF	79°	58°	3250	1.650	NTS-H650

Note : For Spindle dimensions refer accessories page

PART NO	A	B	C	C1	D	F	G	H	J	M	N	N1
MI-H-75-SF	56	145	38	14	19	30	4	54	4.5	M5	5.3	5.5
MI-H-150-SF	55.5	159	41	14	24	35	6	66	4.5	M6	5.3	5.5
MI-H-250-SF	67	188.5	35.5	16	29.5	45	6	75	6.6	M8	6.7	7.7
MI-H-350-SF	98	273	67	22	39.5	60	8	113	8.5	M10	8.5	10.3
MI-H-650-SF	117	332	82	28	45	72	10	145	9.5	M12	10	13.5