

## MI - HORIZONTAL CLAMPING ARM / STRAIGHT BASE - FIXED BUSH

These Straight base horizontal clamping arm with bush to weld in desired position to suite the locking object as per the application. These models feature with the straight base for situation where a horizontal surface is used to mount the clamp, which can be directly bolt mounted or welded to a fixture. These series clamp have high height under the clamping bar compared to the flange base series. This series allows wide opening angle which enables easy loading and unloading of the workpiece. All MI clamps comes with an unique silicon rubber grip which is only manufactured by MI which withstands high temperatures at work place.

These clamps are finished black oxide.

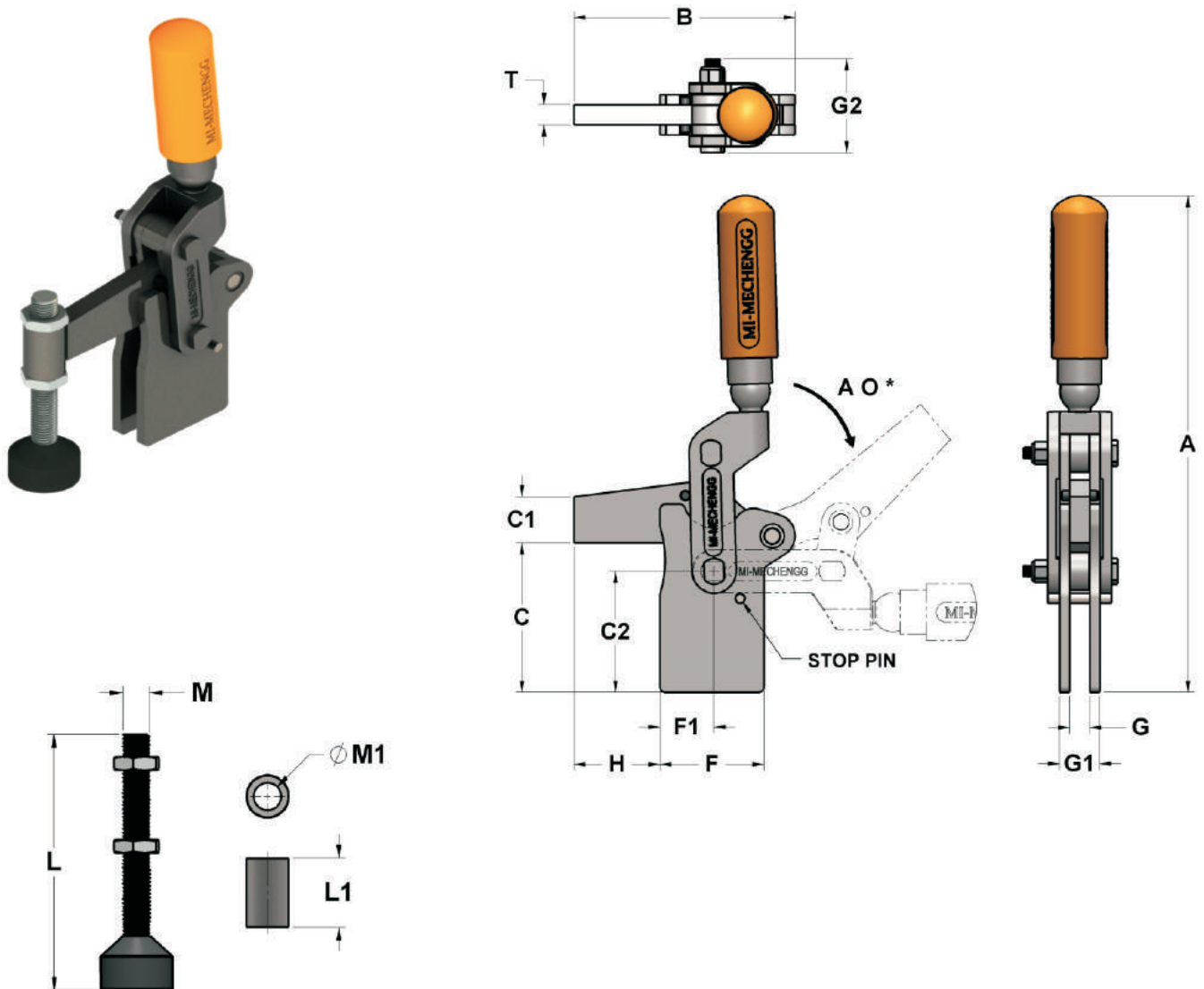

PART NO	AO WITH SP	AO WO SP	A	B	C	C1	C2	F	F1	G	G1	G2	H	L	L1	M	M1	T
MI-AMV-700-WB/SB	140	195	248	110.5	74.7	23	60.5	52	27	10	20	47	43	114	31	12	12.2	10
MI-AMV-1200-WB/SB	130	190	279.3	136.1	74	27	57	56	28	12	24	55	56.6	114	35	12	12.2	12
MI-AMV-2500-WB/SB	140	190	360.1	164	113.3	33	84.5	68	41	16	28	59	63	168	42	16	16.2	16