

## SERIES - MI-V-FMU

### FRONT MOUNT U SHAPED HOLD DOWN ARM

This clamp allow user to mount the clamp on the side of the table / fixture to save precious work surface for other uses. Supplied with Spindle assemblies & Flange washers. Clamp runs with specially designed pre-lubricated bushes for long life cycle. Silicon rubber grip having large grip surface with oil & heat resistance.

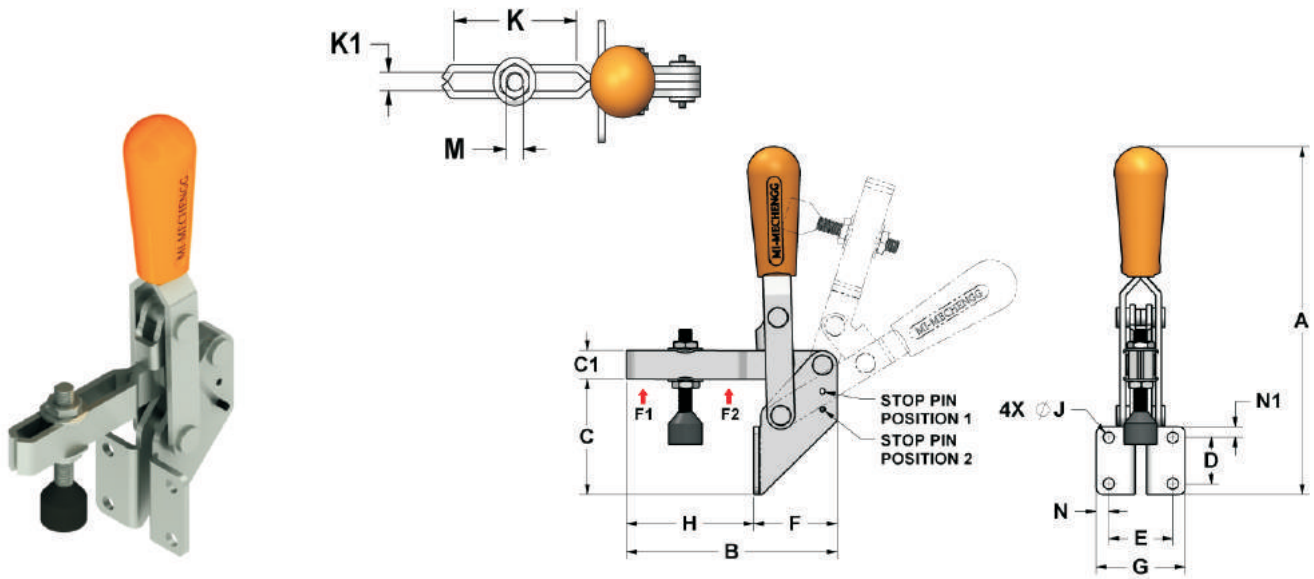

- Material : Steel
- Surface Finish : Electro Zinc - Plated
- Hand Grip : Silicon Rubber
- Clamping Bolt : 8.8 Grade Moulded with NBR

PART NO	ARM OPENS AT PIN 1	HANDLE MOVES AT PIN 1	ARM OPENS AT PIN 2	HANDLE MOVES AT PIN 2	HOLDING F1 (N)	CAPACITY F2 (N)	APPROX $\Delta$ (Kg's)	SPINDLE SUPPLIED (METRIC) PART NO
MI-V-100-FMU	81°	56°	-	-	0420	1000	0.235	NTS-V100
MI-V-150-FMU	46°	46°	112°	70°	0750	2000	0.455	NTS-V150
MI-V-350-FMU	50°	40°	108°	60°	1780	4000	0.950	NTS-V350

Note : For Spindle dimensions refer accessories page

PART NO	A	B	C	C1	D	E	F	G	H	J	K	K1	M	N	N1
MI-V-100-FMU	154	70	64	10	18	41	30	54	40	5	29	6	M6	6.5	8.5
MI-V-150-FMU	198	108	76	16	19	39	45.5	57	63	7	48	9	M8	9	8.5
MI-V-350-FMU	255	151.5	85	21	34	46	60	64	91.5	8	72	10	M10	9	8