

## SERIES - MI-H-FM

### FLANGE BASE FRONT MOUNT

This clamps allow users to mount the clamp on the side of the table / fixture to save precious work surface for other uses. Supplied with Spindle assemblies. Silicon rubber grip having large grip surface with oil & heat resistance.



#### U shaped holding arm

##### MI-H-250-FMU

↑ F1\* :1000 ↑ F2\* :2500 (N)

Arm opens : 79°

Handle moves : 136°

Approx  $\triangle$  (kg's) :0.365

Spindle supplied : NTS-H250

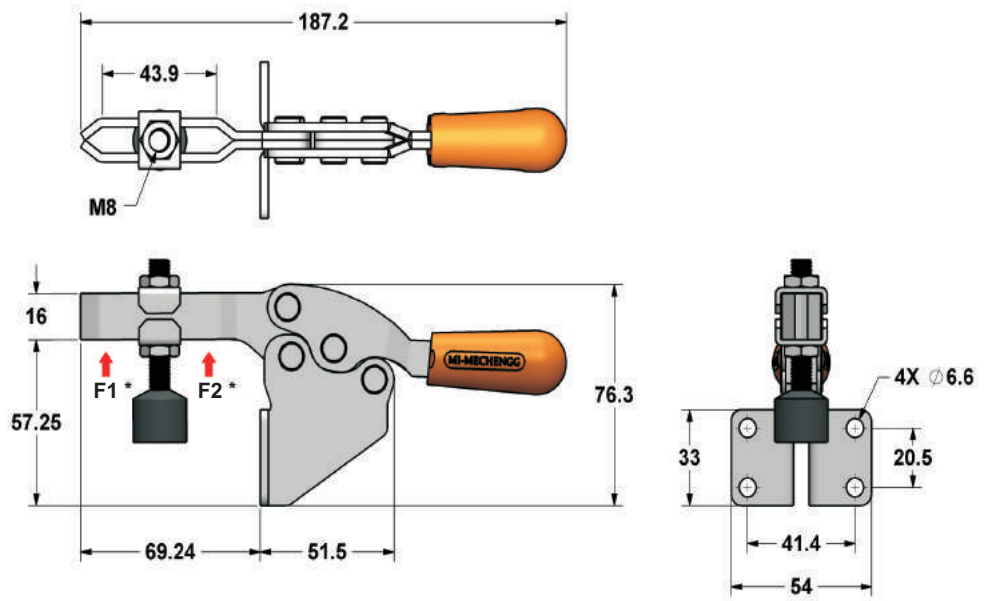

#### Fixed holding arm

##### MI-H-250-FMF

↑ F1\* :1000 (N)

Arm opens : 79°

Handle moves : 136°

Approx  $\triangle$  (kg's) : 0.365

Spindle supplied : NTS-H250

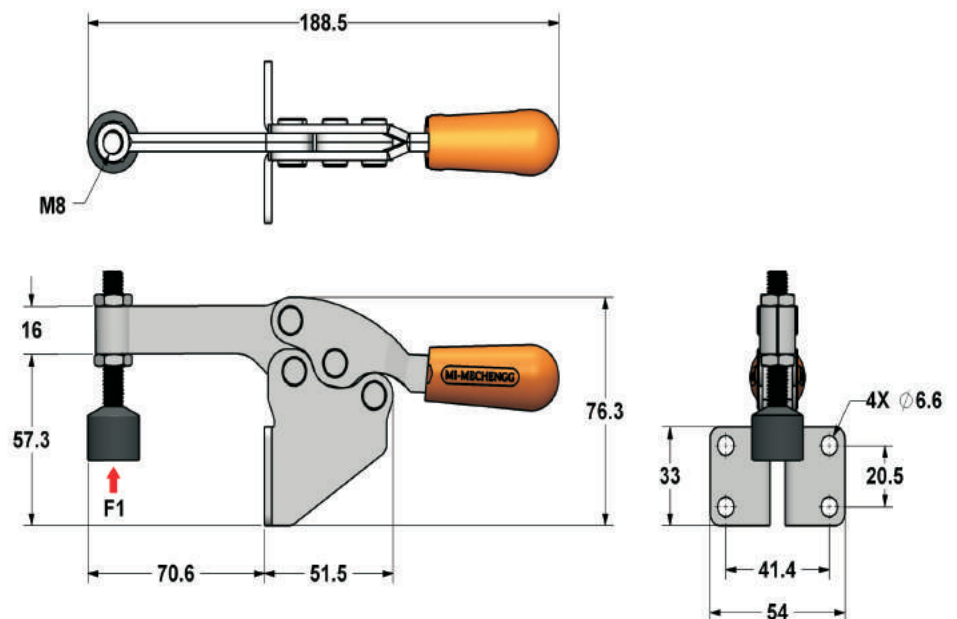

## SERIES - MI-H-FM

### FLANGE BASE FRONT MOUNT

This clamps allow users to mount the clamp on the side of the table / fixture to save precious work surface for other uses. Supplied with spindle assemblies. Silicon rubber grip having large grip surface with oil & heat resistance.



**Solid holding arm**  
**MI-H-350-FMS**

↑ F1\* :1780 ↑ F2\* :4000 (N)  
Arm opens : 79°  
Handle moves : 136°  
Approx  $\Delta$  (kg's) :1.010  
Spindle supplied : NTS-H350  
Spindle Retainer : SRH-350

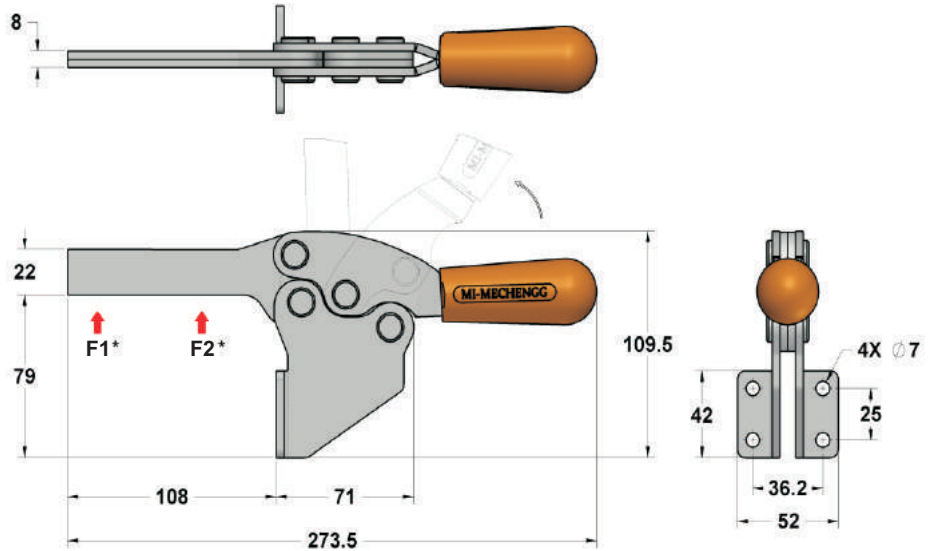

**U shaped holding arm**  
**MI-H-350-FMU**

↑ F1\* :1780 ↑ F2\* :4000 (N)  
Arm opens : 79°  
Handle moves : 136°  
Approx  $\Delta$  (kg's) :1.010  
Spindle supplied : NTS-H350

